

CSIR-Central Scientific Instruments Organisation

Ref. No. CSIO/2024/MSI 02012024/01

Dated 2nd January 2024

CSIO intends to purchase the below mentioned fabricated items

S No.	Items	Qty
1	Alloy Steel Cylinder OD 50mm, ID 40mm L 225mm	01 No.
2	Piston Shaft with Pressure Gauge OD 25mm L 125mm	01 No.
3	Hydraulic Plunger Plate with Handle LxBxH 50x130x150mm	01 No.
4	Container for Fluid LxBxH 250x300x300mm	01 No.
5	Horizontal Support Bar LxBxH 454x65x25mm	01 No.
6	Aluminum Pressure Plate LxBxH 210x110x16mm	01 No.

Interested firm who can supply the above items, can send their quotation through mail to sanjaysharma@csio.res.in on or before 9th January 2024

1 Delivery at CSIO Chandigarh

2 Taxes as applicable



(Sanjay Sharma)

MDF –Pr. Tech. Officer

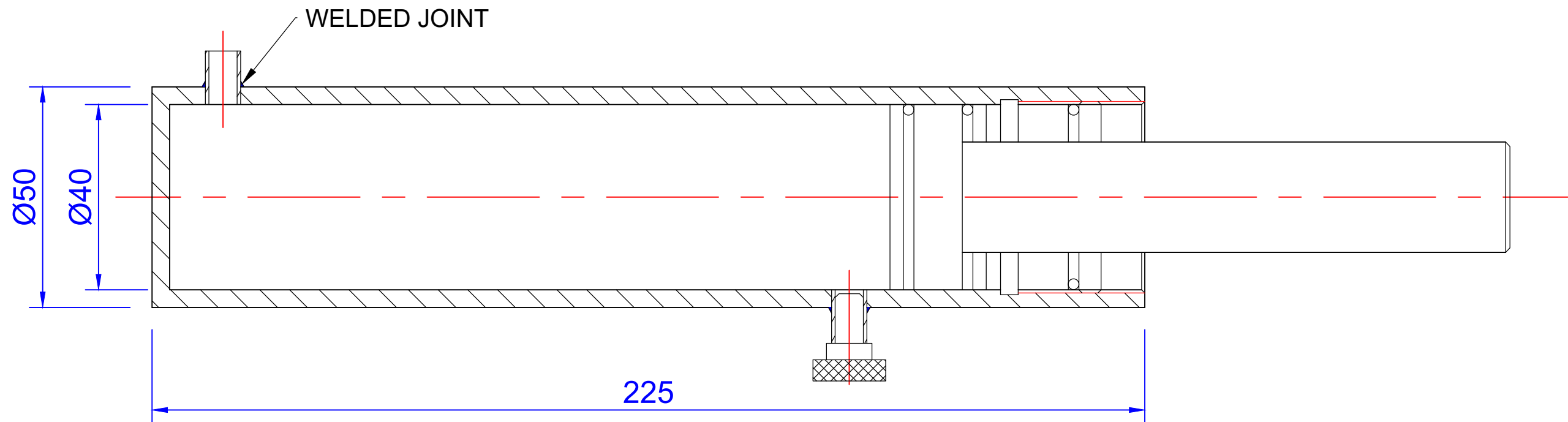

Material Alloy Steel
Scale 1:1
No off 01

Alloy Steel Cylinder

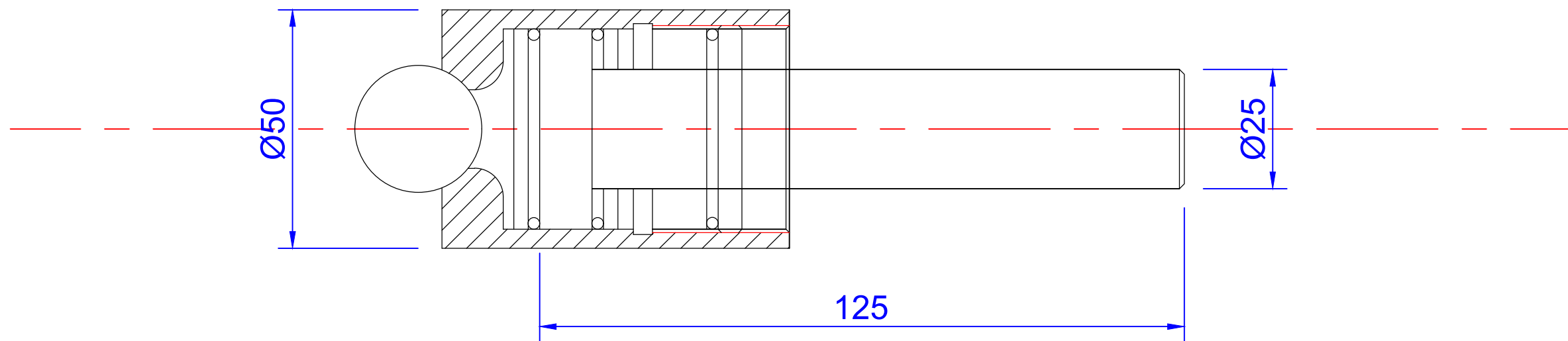

Material Alloy Steel
Scale 1:1
No off 01

Piston Shaft with Pressure Gauge

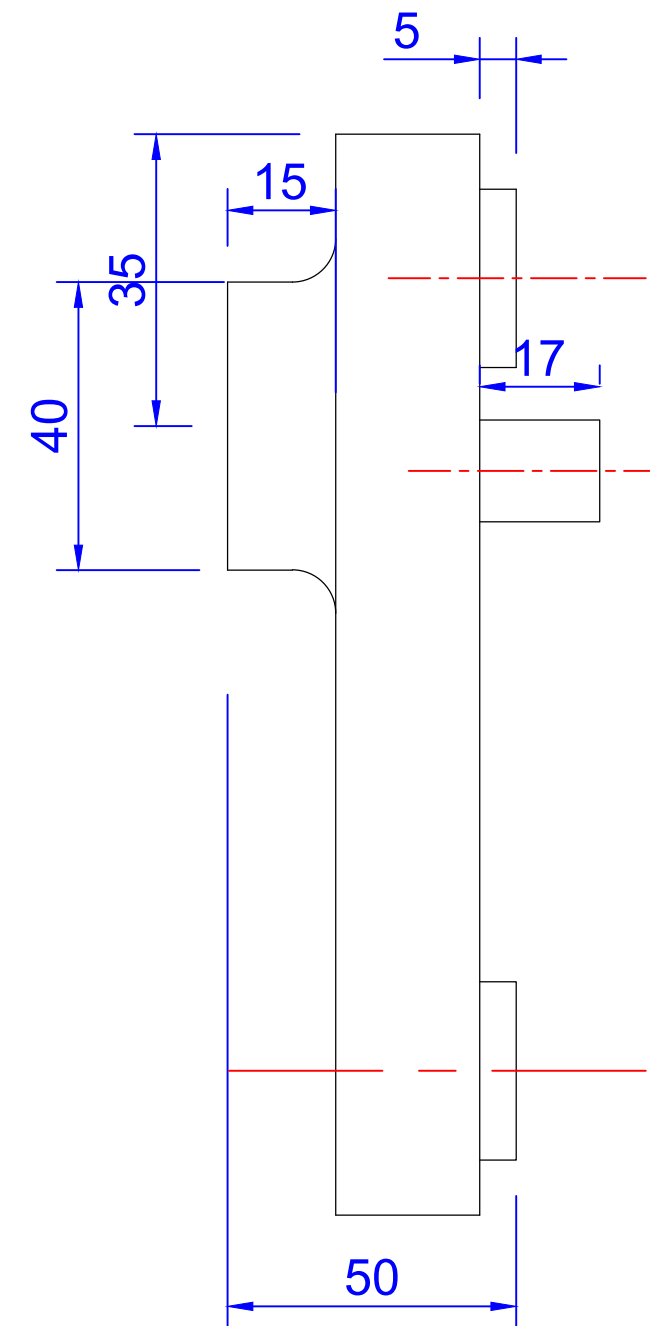
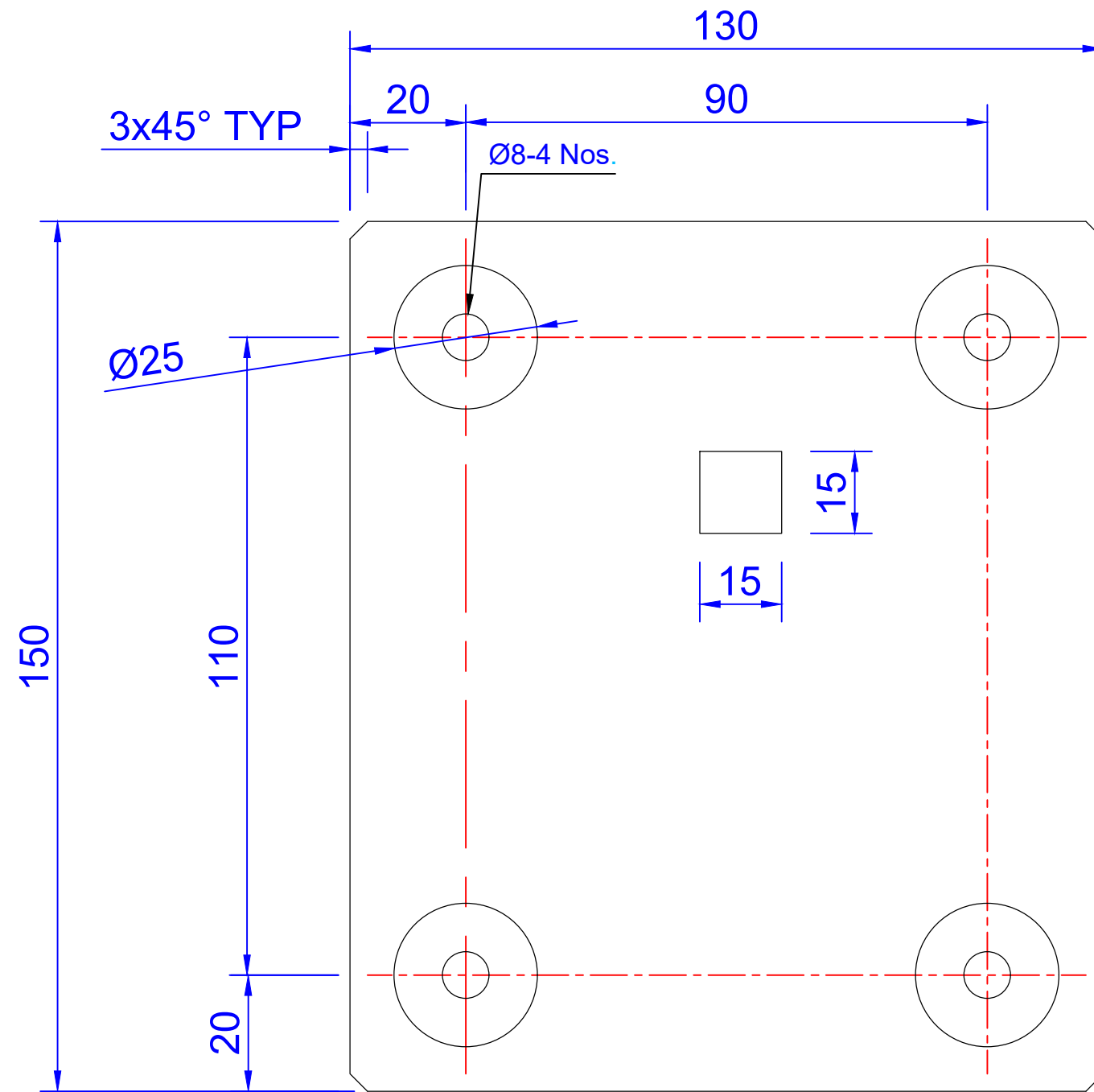

Material Alloy Steel
 Scale 1:1
 No off 01

Hydraulic Plunger Plate with Handle

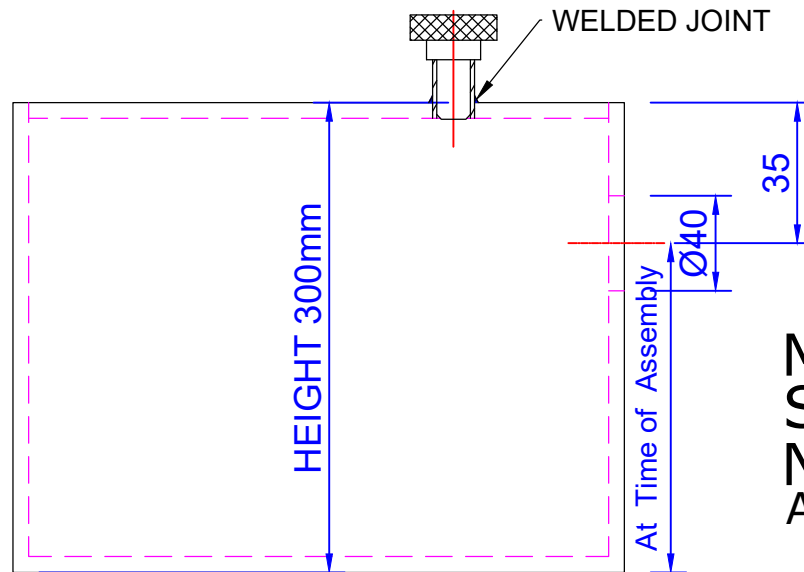
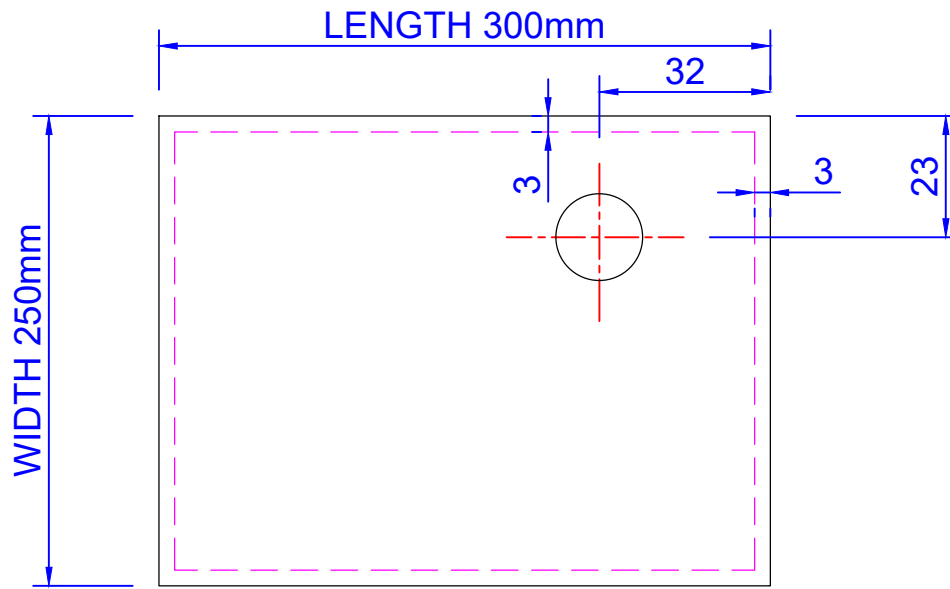

Material Alloy STEEL
Scale 1:1
No off 01
All joints are Welded and Sealed

Container for Fluid

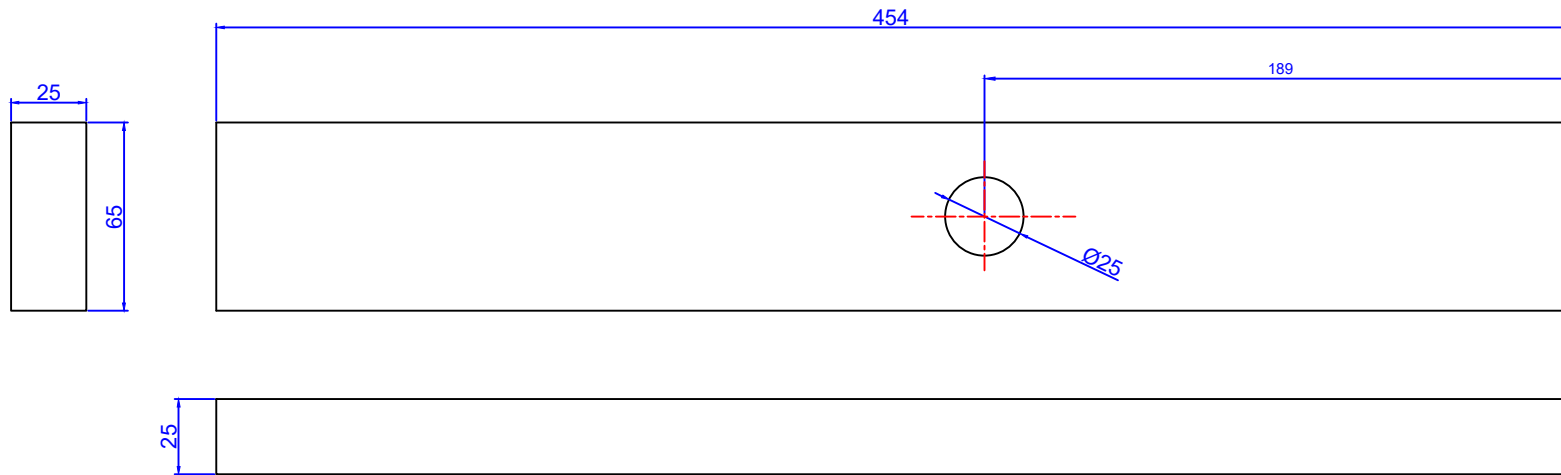

HORIZONTAL SUPPORT BAR

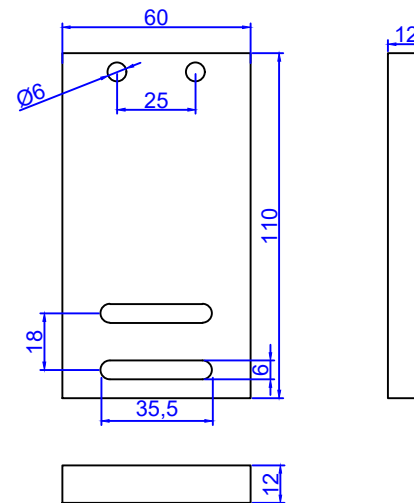

SUPPORT BAR

Material Mild Steel -MS
 Scale 1:1
 No off 01
 HORIZONTAL SUPPORT BAR

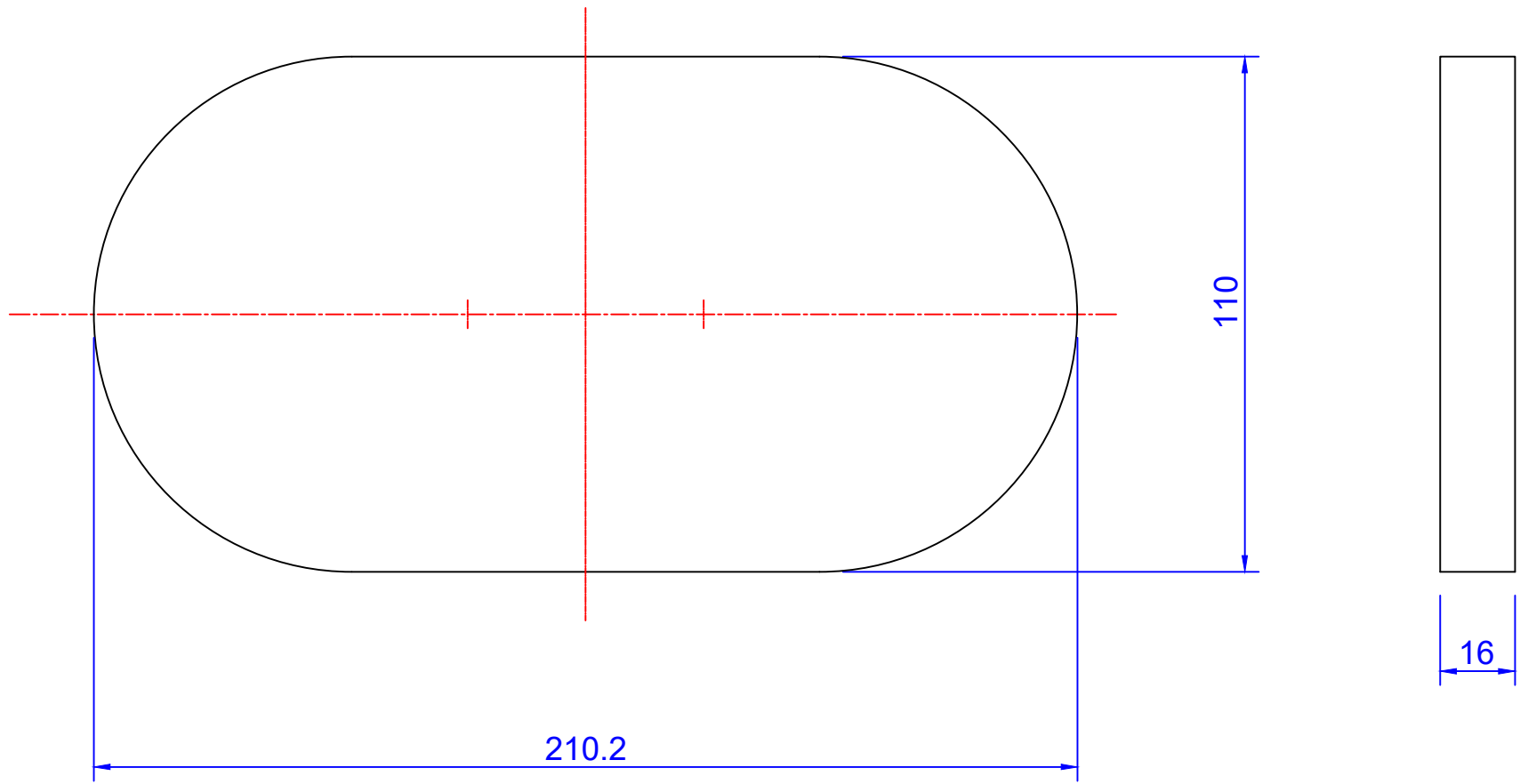

Material Al Alloy
Scale 1:1
No off 01

Alumium Pressure Plate