

FABRICATION OF COMPONENTS AS PER DWG.

Ref: MDF/ML//24/01/01

1. THE ORDER SHOULD NOT BE PREFERABLY SPLITTED. THE COMPREHENSIVE QUOTE CONSIDERING AVAILABILITY OF ALL COMPONENTS, FOR AT CSIO WILL BE CONSIDERED.
2. THE REQUIRED QUANTITY IS MENTIONED AND COMPONENTS SHOULD BE SEALED/PACKED AS PER THE ORIGINAL FACTORY PACKING. IF FOUND DAMAGED, WILL BE RETURNED.
3. THE PRICE SHOULD BE INCLUDING EX-CSIO DELIVERY.
4. THE VALID COC SHOULD BE SHARED.
5. PAYMENT AND OTHER THINGS AS PER CSIO NORMS
6. PL MAIL AT harry.garg@csio.res.in, pme@csio.res.in, sunil.kumar@csio.res.in
7. QUOTE TIME 7 DAYS FROM DATE OF TENDER.
8. THE DETAILS OF USER WILL NOT BE SHARED.
9. SUPPLIER/OEM TO SHARE THE DELIVERY TIMELINES AFTER PO AND PAYMENT TERMS. PURCHASE OF COMPONENTS/ PO IS PURELY THE PREROGATIVE OF CSIO
10. PL QUOTE WITH 18% GST AND DELIVERY TIMELINES OF 30 DAYS. SHARE AND ATTACH RELEVANT COMPANY DOCUMENTS.
11. KINDLY FILL ALL THE RELEVANT FIELDS MENTIONED IN THE TENDER AND STRIKEOUT WHICHEVER IS NOT APPLICABLE.

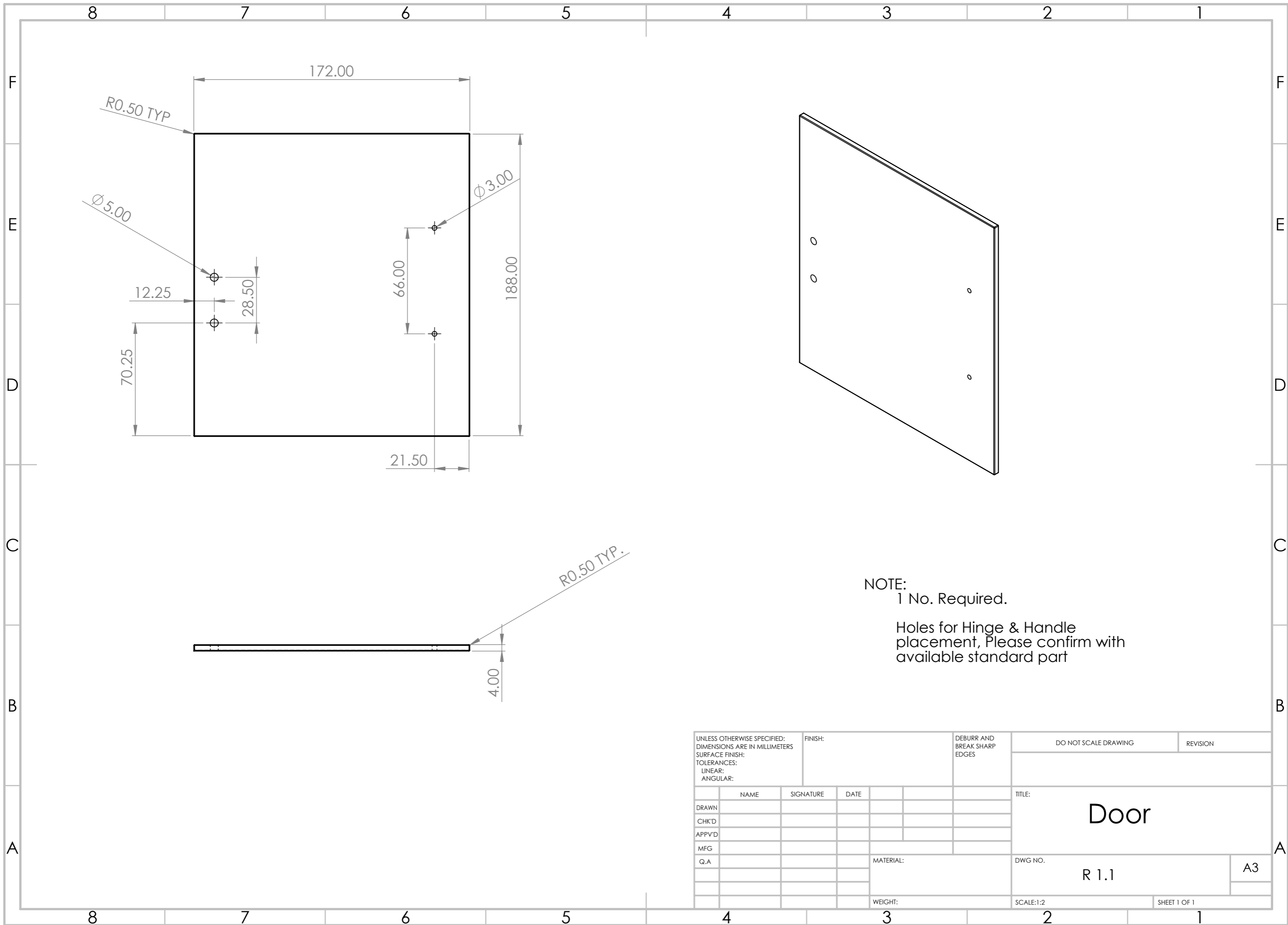

UNLESS OTHERWISE SPECIFIED: DIMENSIONS ARE IN MILLIMETERS SURFACE FINISH: TOLERANCES: LINEAR: ANGULAR:			FINISH:		DEBURR AND BREAK SHARP EDGES		DO NOT SCALE DRAWING		REVISION			
							TITLE: Door					
							DWG NO. R 1.1			A3		
							WEIGHT:		SCALE:1:2		SHEET 1 OF 1	
DRAWN	NAME	SIGNATURE	DATE									
CHK'D												
APPV'D												
MFG												
Q.A												

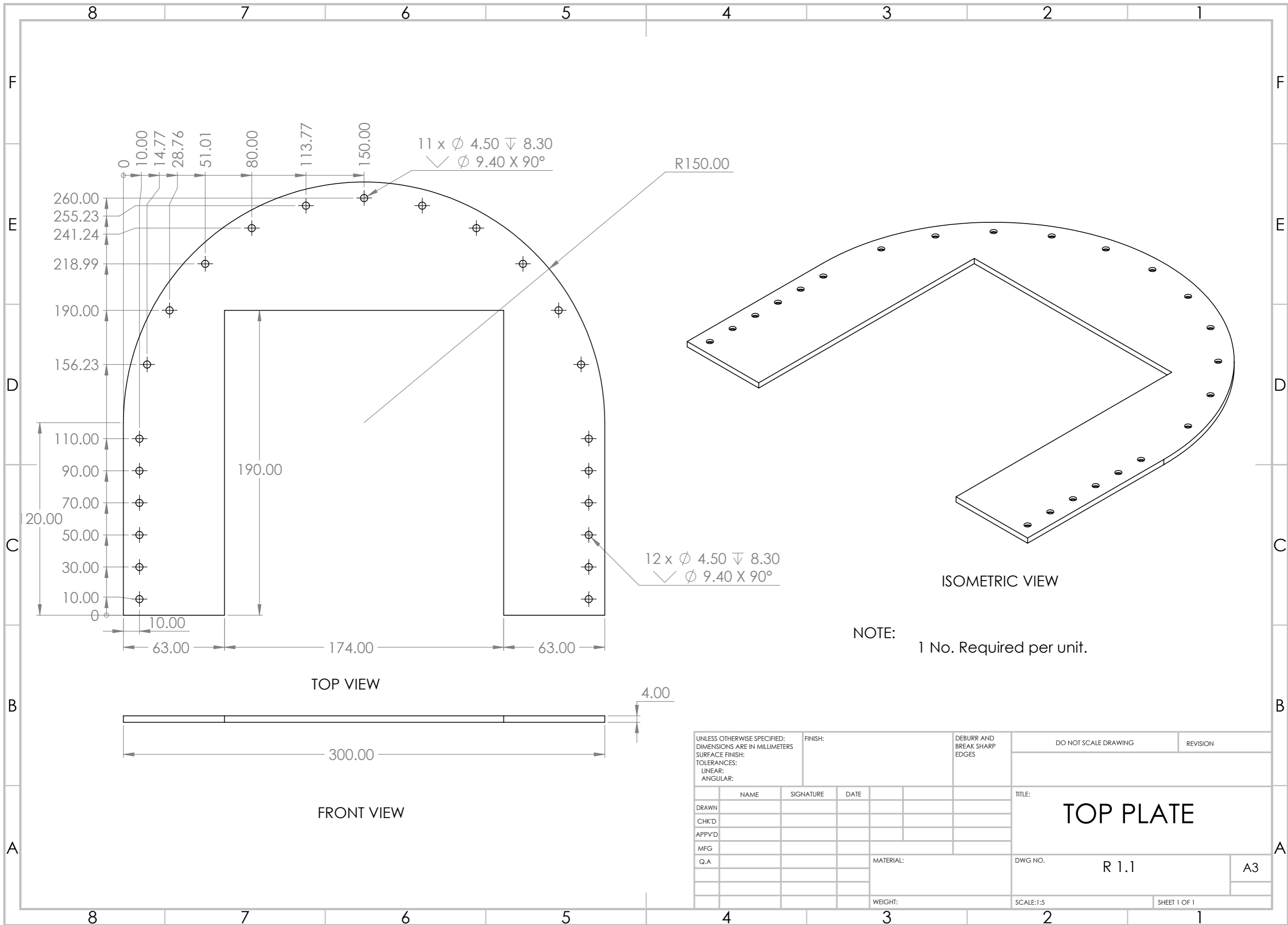

UNLESS OTHERWISE SPECIFIED: DIMENSIONS ARE IN MILLIMETERS				FINISH:		DEBURR AND BREAK SHARP EDGES		DO NOT SCALE DRAWING		REVISION	
SURFACE FINISH:								TITLE: TOP PLATE			
TOLERANCES:											
LINEAR:											
ANGULAR:											
DRAWN		NAME		SIGNATURE		DATE		DWG NO.		R 1.1	
CHK'D								SCALE:1:5		SHEET 1 OF 1	
APPV'D								MATERIAL:		A3	
MFG								WEIGHT:			
Q.A											

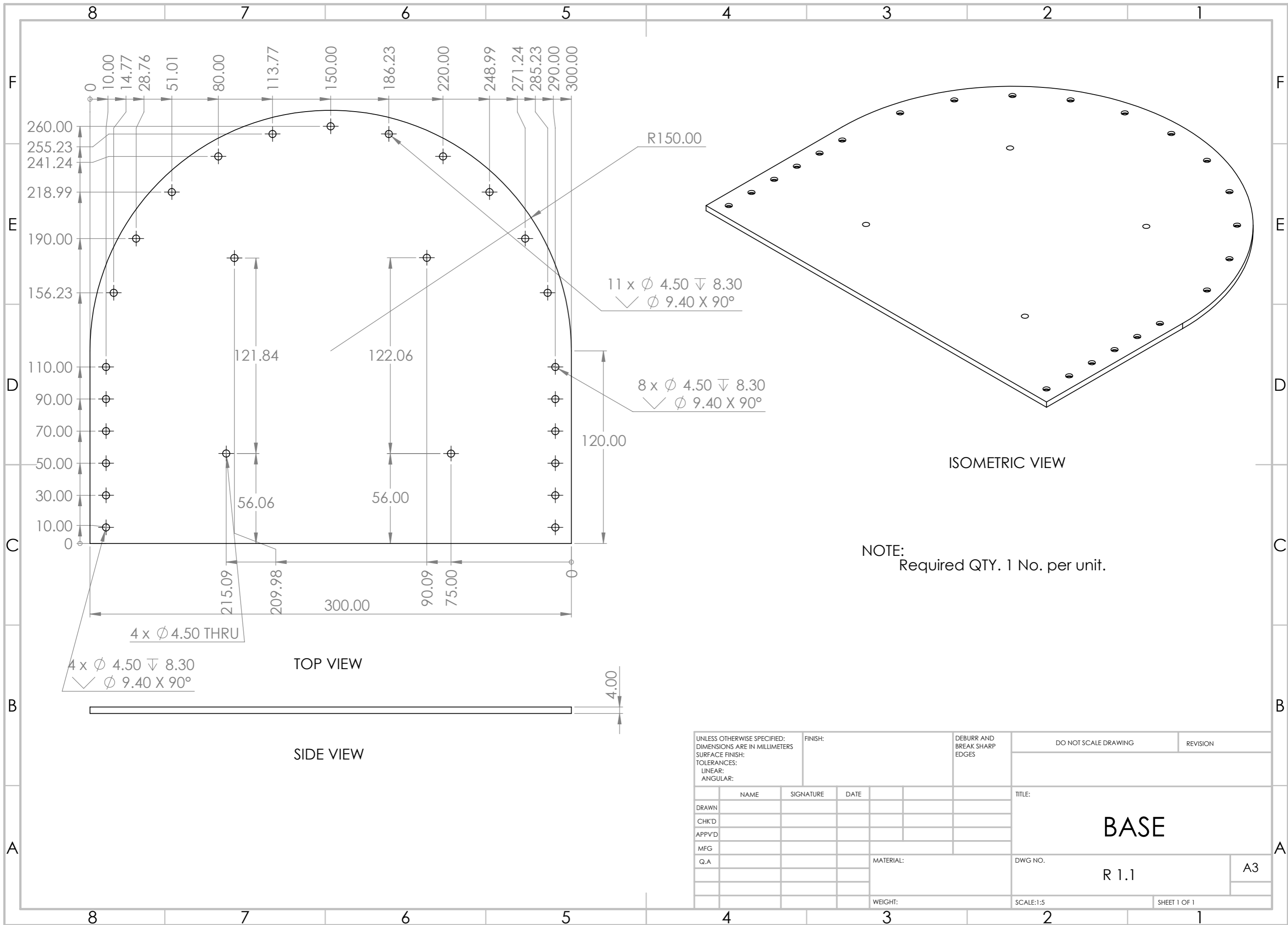

8 7 6 5 4 3 2 1

F F

E E

D D

C C

B B

A A

0 10.00 14.77 28.76 51.01 80.00 113.77 150.00 186.23 220.00 248.99 271.24 285.23 290.00 300.00

260.00
255.23
241.24
218.99
190.00
156.23
110.00
90.00
70.00
50.00
30.00
10.00
0

R150.00

11 x ϕ 4.50 ∇ 8.30
 ∇ ϕ 9.40 X 90°

8 x ϕ 4.50 ∇ 8.30
 ∇ ϕ 9.40 X 90°

120.00

121.84

122.06

56.06

56.00

215.09

209.98

300.00

90.09

75.00

4 x ϕ 4.50 THRU

4 x ϕ 4.50 ∇ 8.30
 ∇ ϕ 9.40 X 90°

TOP VIEW

SIDE VIEW

4.00

ISOMETRIC VIEW

NOTE:
Required QTY. 1 No. per unit.

UNLESS OTHERWISE SPECIFIED: DIMENSIONS ARE IN MILLIMETERS				FINISH:		DEBURR AND BREAK SHARP EDGES		DO NOT SCALE DRAWING		REVISION	
SURFACE FINISH:											
TOLERANCES:											
LINEAR:											
ANGULAR:											
DRAWN		NAME		SIGNATURE		DATE		TITLE:		BASE	
CHK'D											
APPV'D											
MFG											
Q.A								MATERIAL:		DWG NO.	
										R 1.1	
								WEIGHT:		SCALE:1:5	
										SHEET 1 OF 1	
										A3	

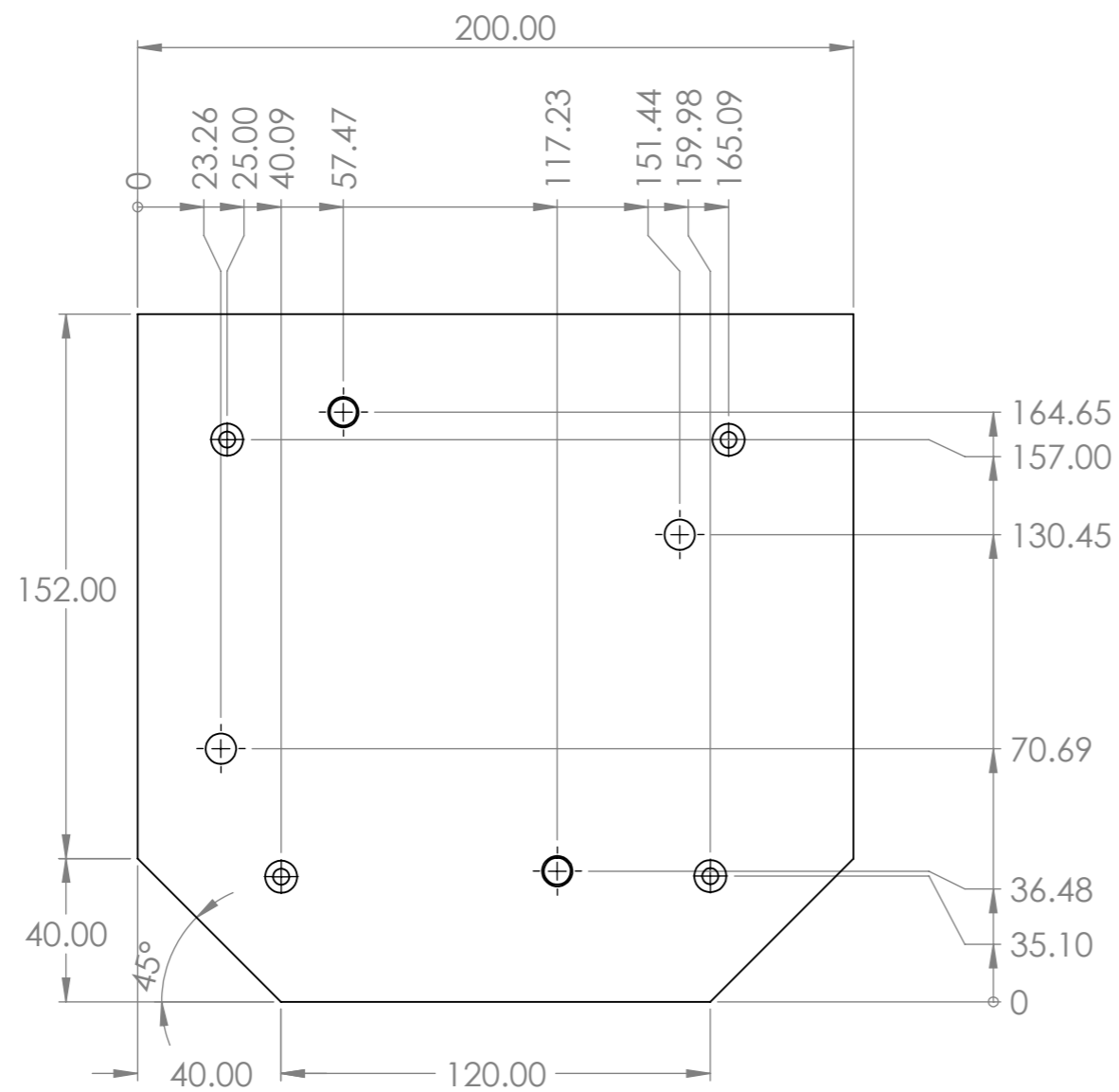

TOP VIEW

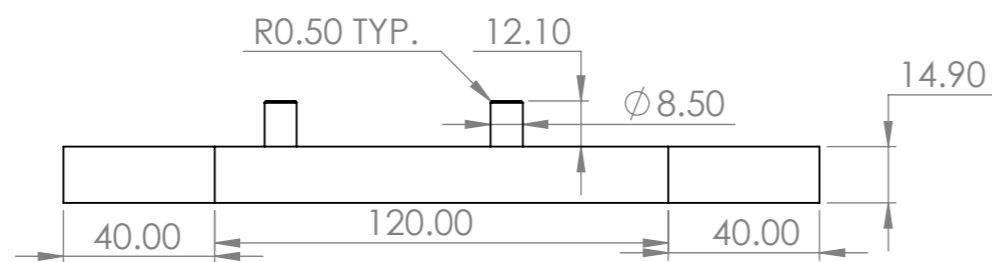

FRONT VIEW

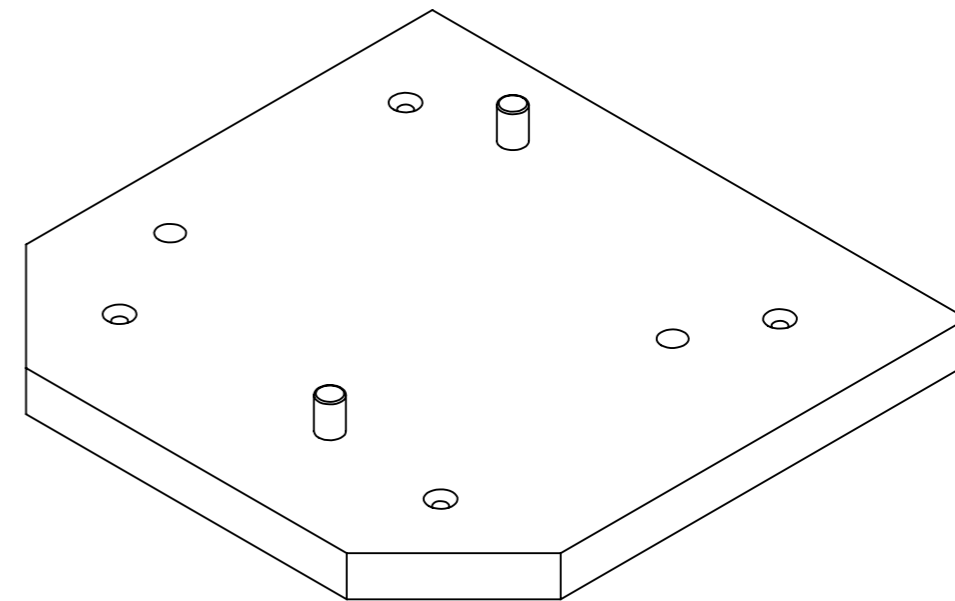

ISOMETRIC VIEW

NOTE:
Required QTY. - 1 No. per unit.

UNLESS OTHERWISE SPECIFIED: DIMENSIONS ARE IN MILLIMETERS SURFACE FINISH: TOLERANCES: LINEAR: ANGULAR:			FINISH:		DEBURR AND BREAK SHARP EDGES		DO NOT SCALE DRAWING		REVISION		
DRAWN							TITLE: Base Slider Plate				
CHK'D							DWG NO. R 1.1				
APPV'D							A3				
MFG							SCALE:1:2				
Q.A							SHEET 1 OF 1				
MATERIAL:							WEIGHT:				

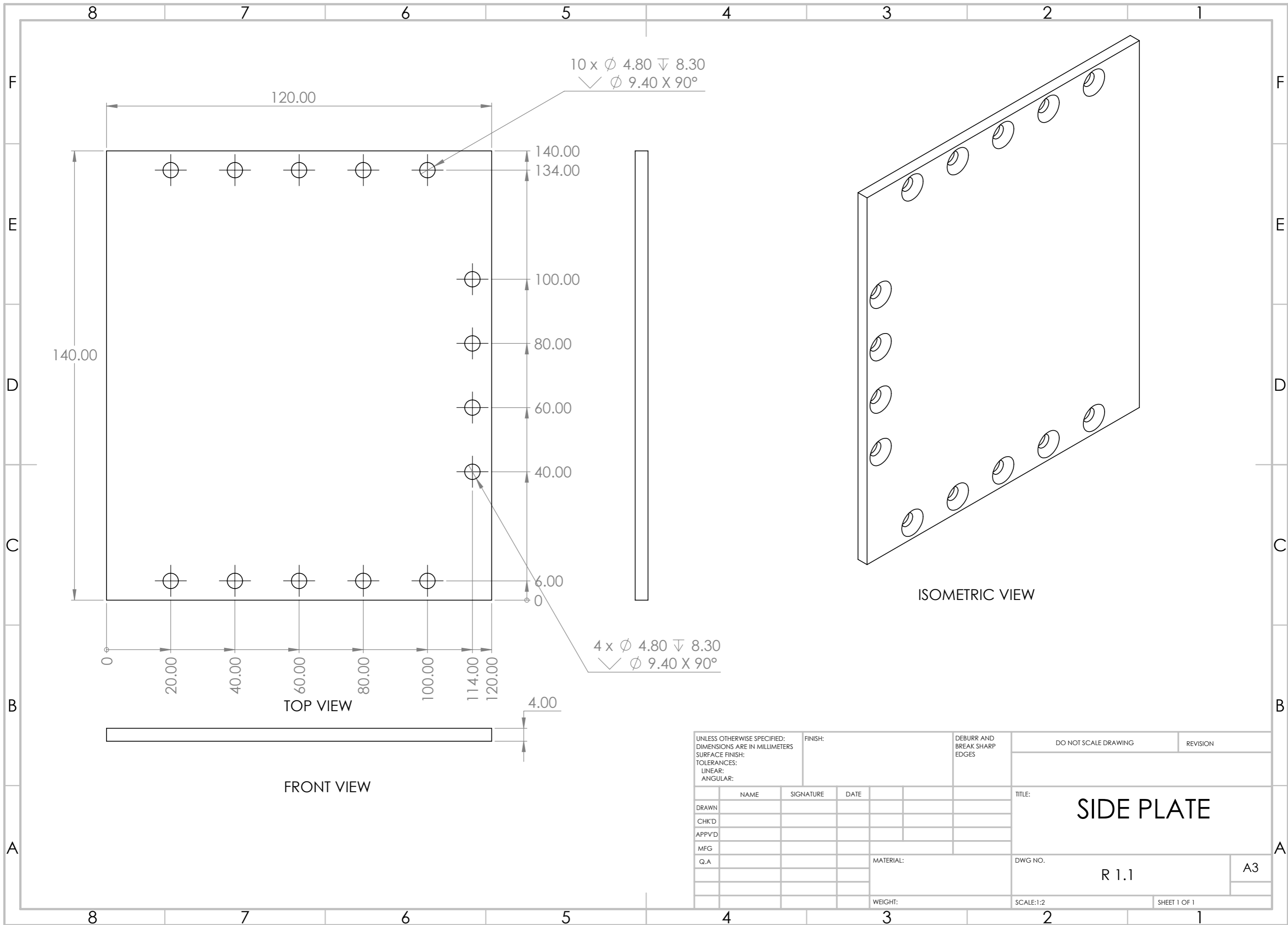

UNLESS OTHERWISE SPECIFIED: DIMENSIONS ARE IN MILLIMETERS SURFACE FINISH: TOLERANCES: LINEAR: ANGULAR:			FINISH:		DEBURR AND BREAK SHARP EDGES		DO NOT SCALE DRAWING		REVISION		
						TITLE: SIDE PLATE					
						DWG NO. R 1.1					
						SCALE:1:2					
						SHEET 1 OF 1					
DRAWN		NAME		SIGNATURE		DATE		MATERIAL:		A3	
CHK'D								WEIGHT:			
APPV'D											
MFG											
Q.A											

8 7 6 5 4 3 2 1

F
E
D
C
B
A

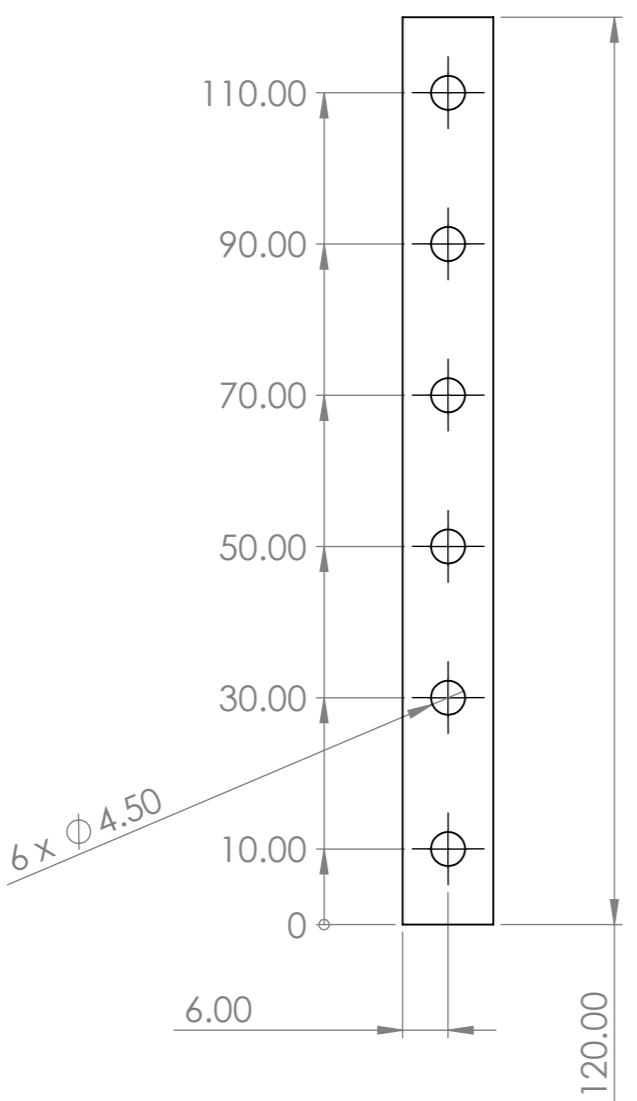

TOP VIEW

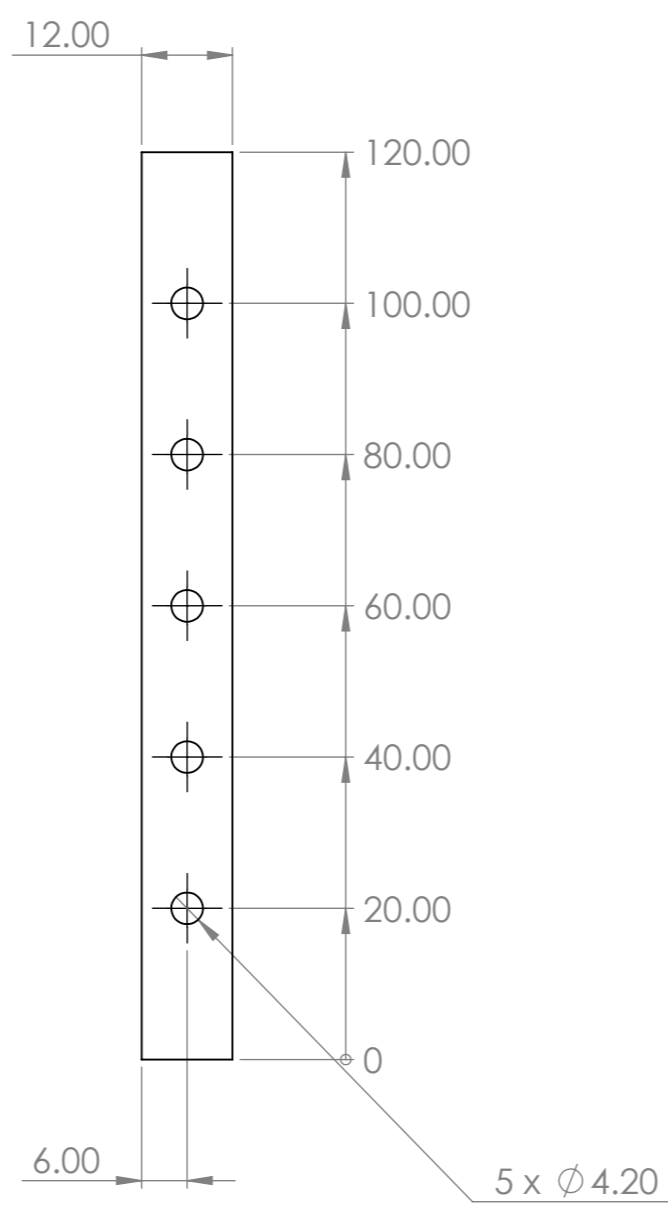

SIDE VIEW

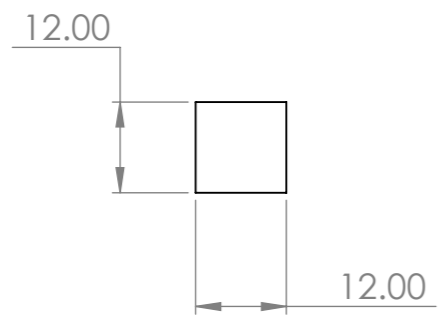

FRONT VIEW

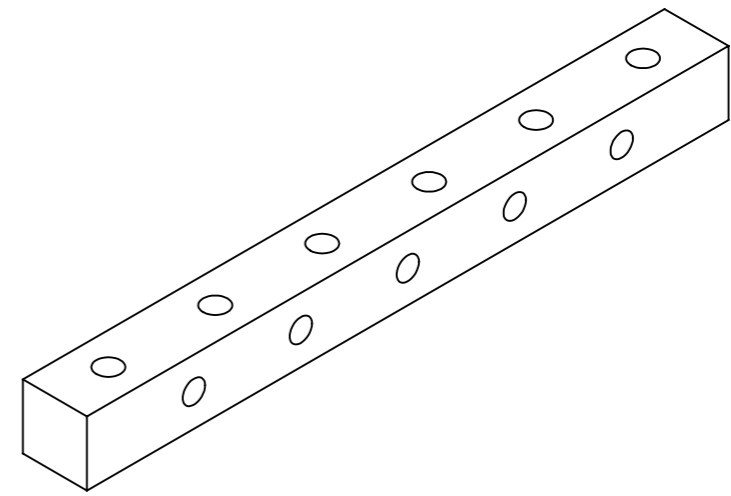

ISOMETRIC VIEW

NOTE:
No. Required - 4 No.s per unit.

UNLESS OTHERWISE SPECIFIED: DIMENSIONS ARE IN MILLIMETERS SURFACE FINISH: TOLERANCES: LINEAR: ANGULAR:			FINISH:		DEBURR AND BREAK SHARP EDGES		DO NOT SCALE DRAWING		REVISION		
						TITLE:					
DRAWN			NAME			SIGNATURE			DATE		
CHK'D											
APPV'D											
MFG											
Q.A						MATERIAL:			DWG NO.		
									DEC23cJoint plate H		
						WEIGHT:			SCALE:1:1		
									SHEET 1 OF 1		

8 7 6 5 4 3 2 1

F
E
D
C
B
A

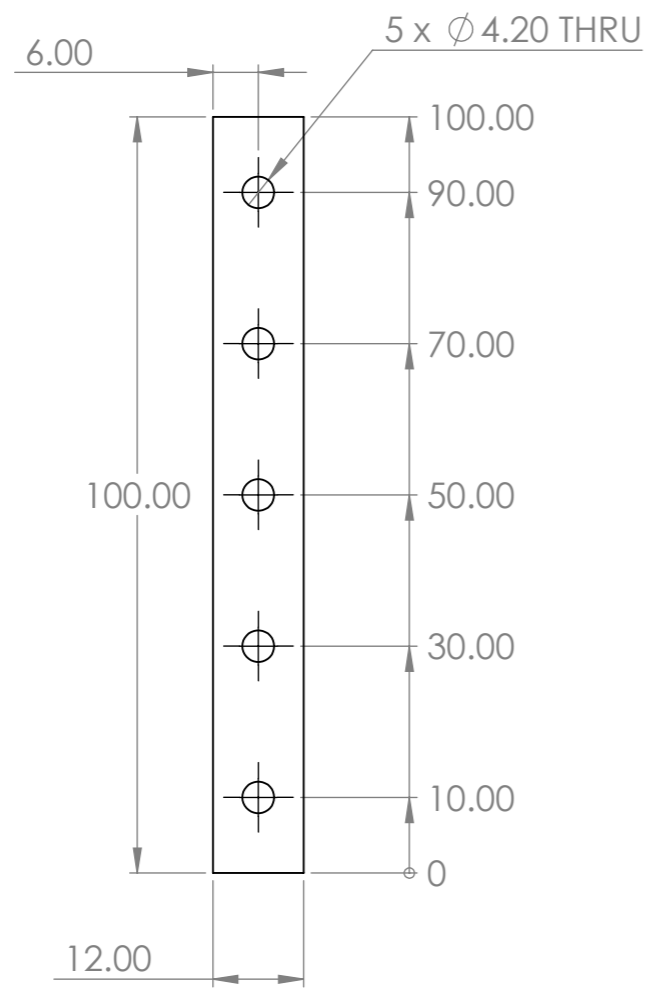

TOP VIEW

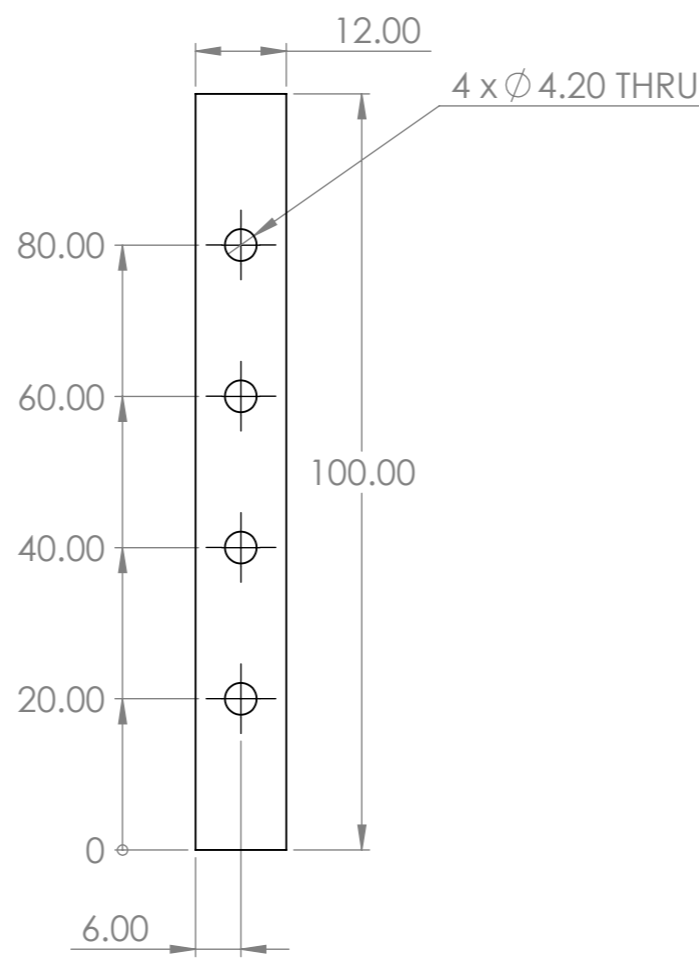

SIDE VIEW

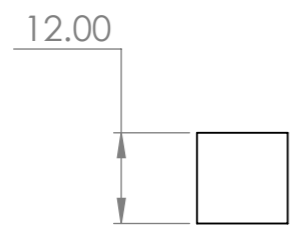

FRONT VIEW

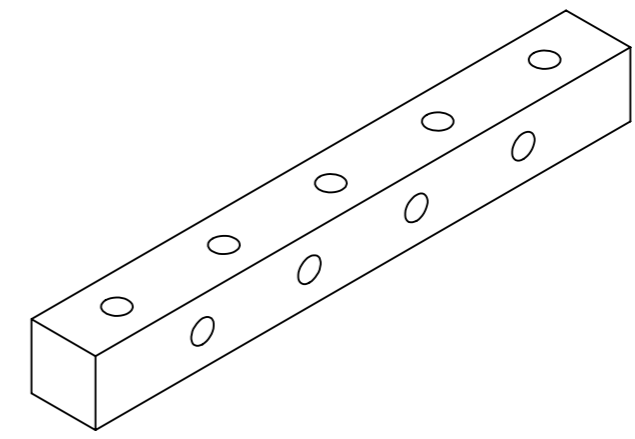

ISOMETRIC VIEW

NOTE:
No. required - 2 per unit.

UNLESS OTHERWISE SPECIFIED: DIMENSIONS ARE IN MILLIMETERS SURFACE FINISH: TOLERANCES: LINEAR: ANGULAR:			FINISH:		DEBURR AND BREAK SHARP EDGES		DO NOT SCALE DRAWING		REVISION		
DRAWN			NAME		SIGNATURE		DATE		TITLE:		
CHK'D											
APPV'D											
MFG											
Q.A							MATERIAL:		DWG NO.		
									DEC23cPart14		
							WEIGHT:		SCALE:1:1		
									SHEET 1 OF 1		
									A3		

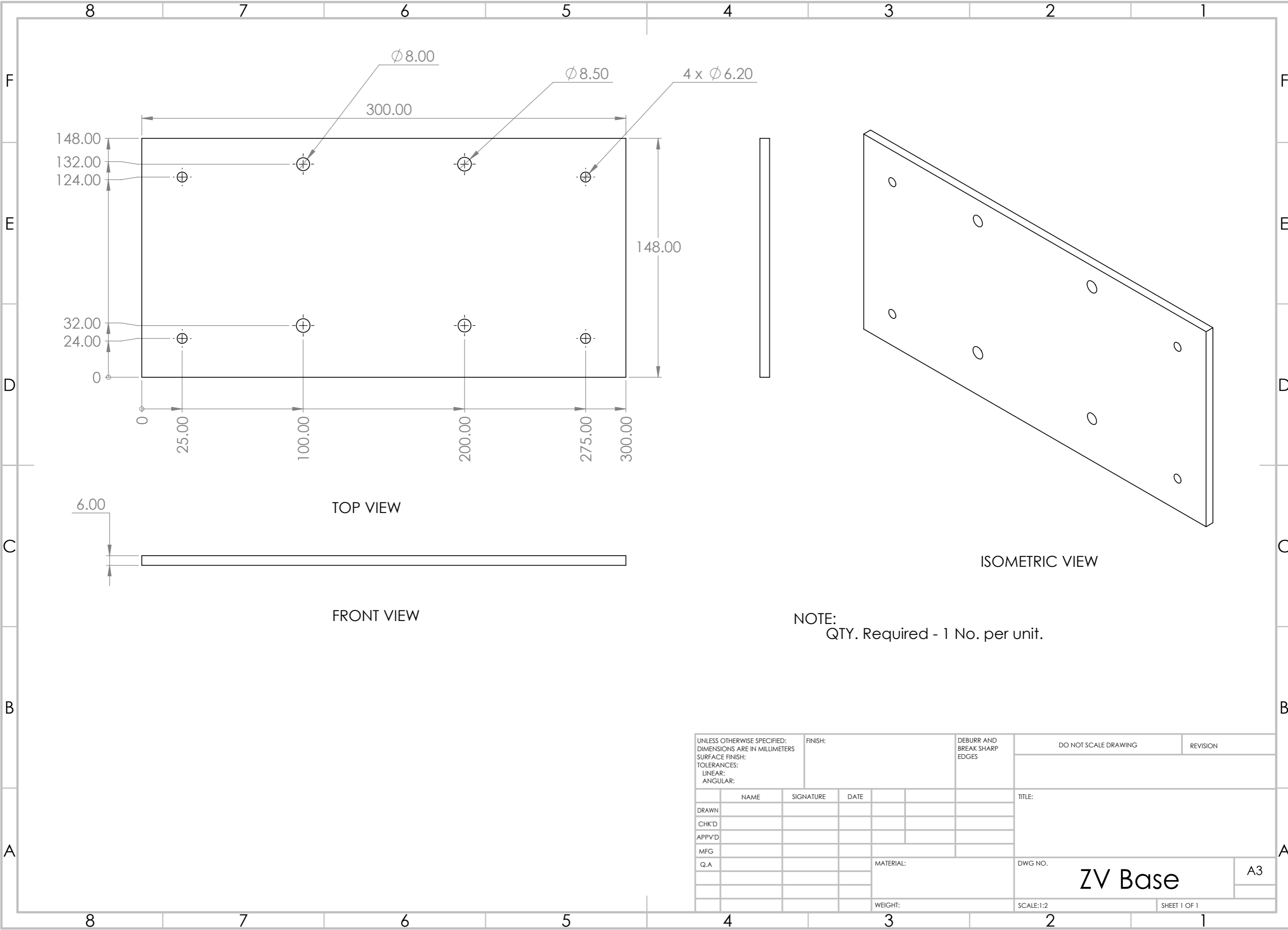

NOTE:
QTY. Required - 1 No. per unit.

UNLESS OTHERWISE SPECIFIED: DIMENSIONS ARE IN MILLIMETERS SURFACE FINISH: TOLERANCES: LINEAR: ANGULAR:				FINISH:		DEBURR AND BREAK SHARP EDGES		DO NOT SCALE DRAWING		REVISION	
DRAWN				NAME		SIGNATURE		DATE		TITLE:	
CHK'D											
APPV'D											
MFG											
Q.A								MATERIAL:		DWG NO.	
										ZV Base	
								WEIGHT:		SCALE:1:2	
										SHEET 1 OF 1	
										A3	

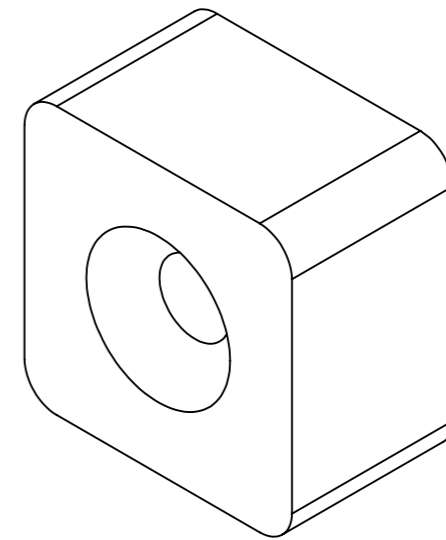
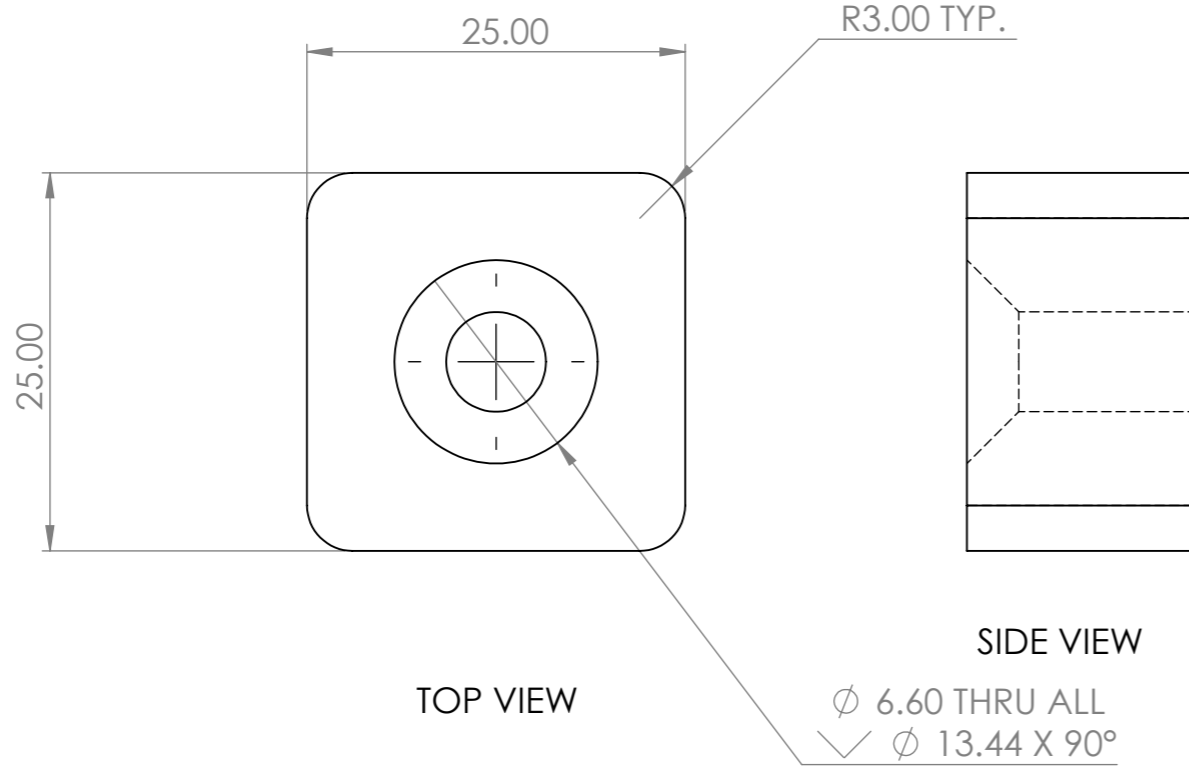

ISOMETRIC VIEW

NOTE:
QTY. Required - 4 No. per unit.

UNLESS OTHERWISE SPECIFIED: DIMENSIONS ARE IN MILLIMETERS				FINISH:		DEBURR AND BREAK SHARP EDGES		DO NOT SCALE DRAWING		REVISION	
SURFACE FINISH:											
TOLERANCES:											
LINEAR:											
ANGULAR:											
DRAWN		NAME		SIGNATURE		DATE		TITLE:			
CHK'D											
APPV'D											
MFG											
Q.A								MATERIAL:		DWG NO.	
										A3	
								WEIGHT:		SCALE:2:1	
										SHEET 1 OF 1	

STANDOFF

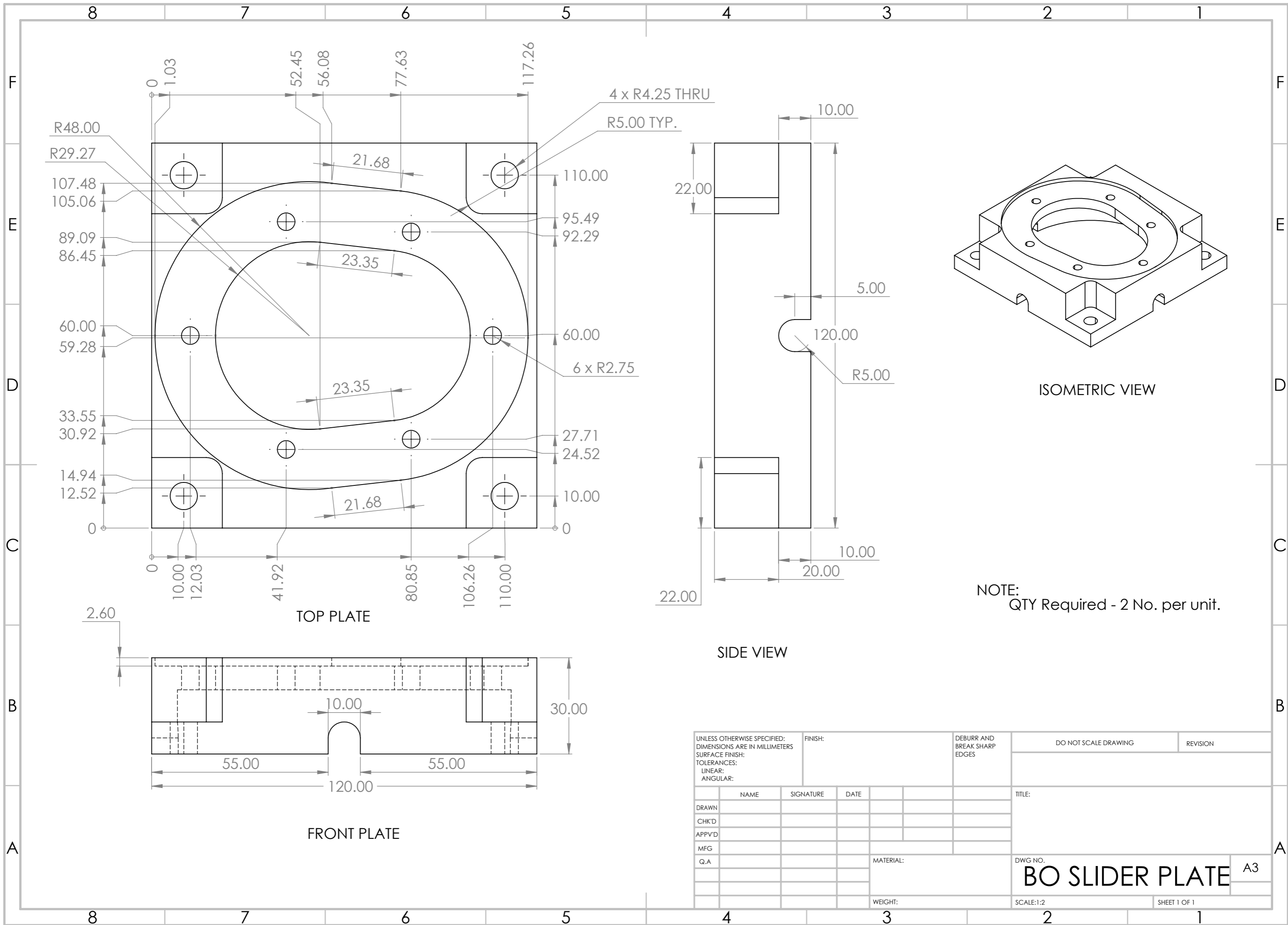

UNLESS OTHERWISE SPECIFIED: DIMENSIONS ARE IN MILLIMETERS SURFACE FINISH: TOLERANCES: LINEAR: ANGULAR:			FINISH:		DEBURR AND BREAK SHARP EDGES		DO NOT SCALE DRAWING		REVISION		
DRAWN			SIGNATURE		DATE		TITLE:				
CHK'D											
APPV'D											
MFG											
Q.A					MATERIAL:		DWG NO.		A3		
					WEIGHT:		SCALE:1:2		SHEET 1 OF 1		
								BO SLIDER PLATE			

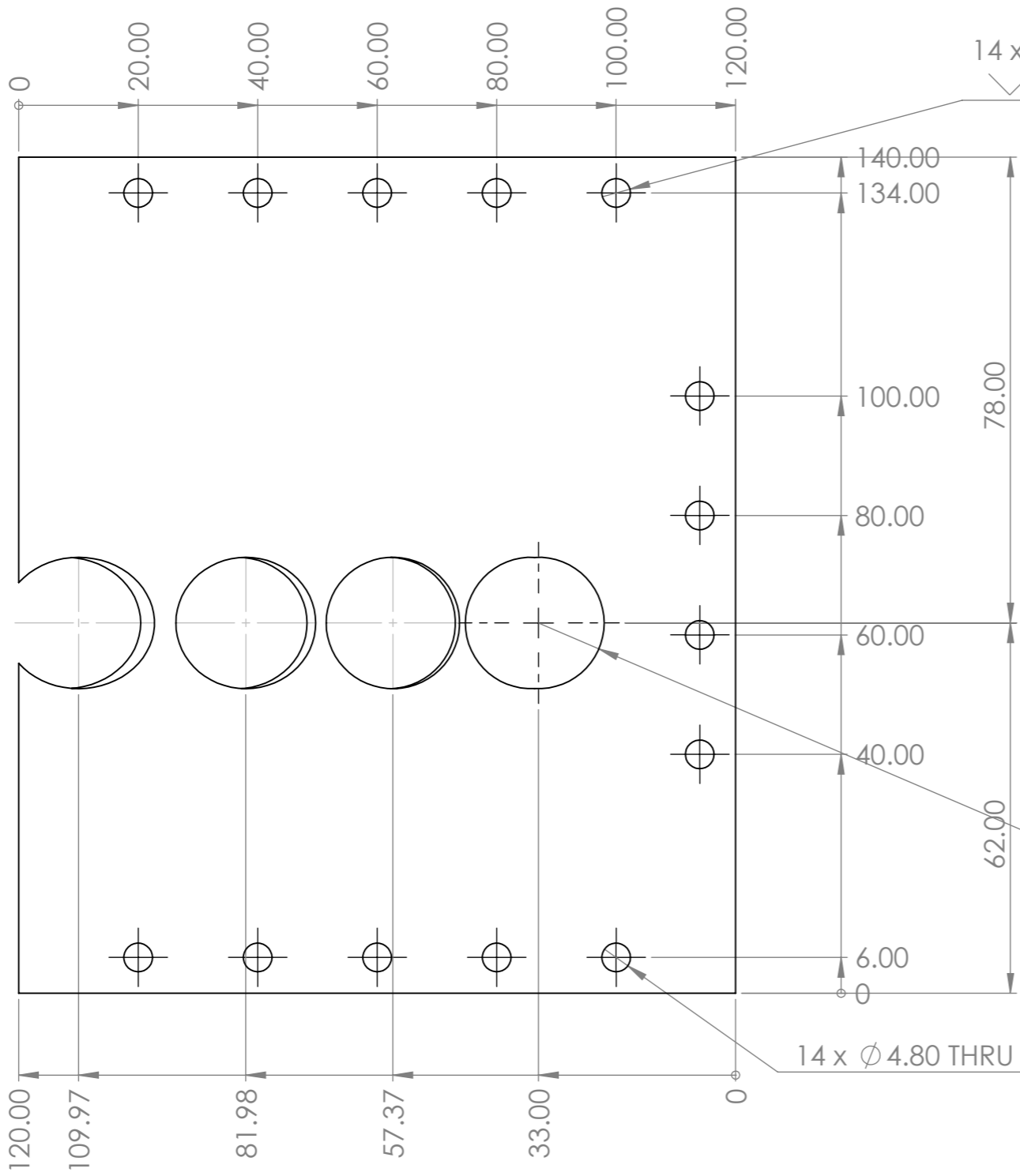
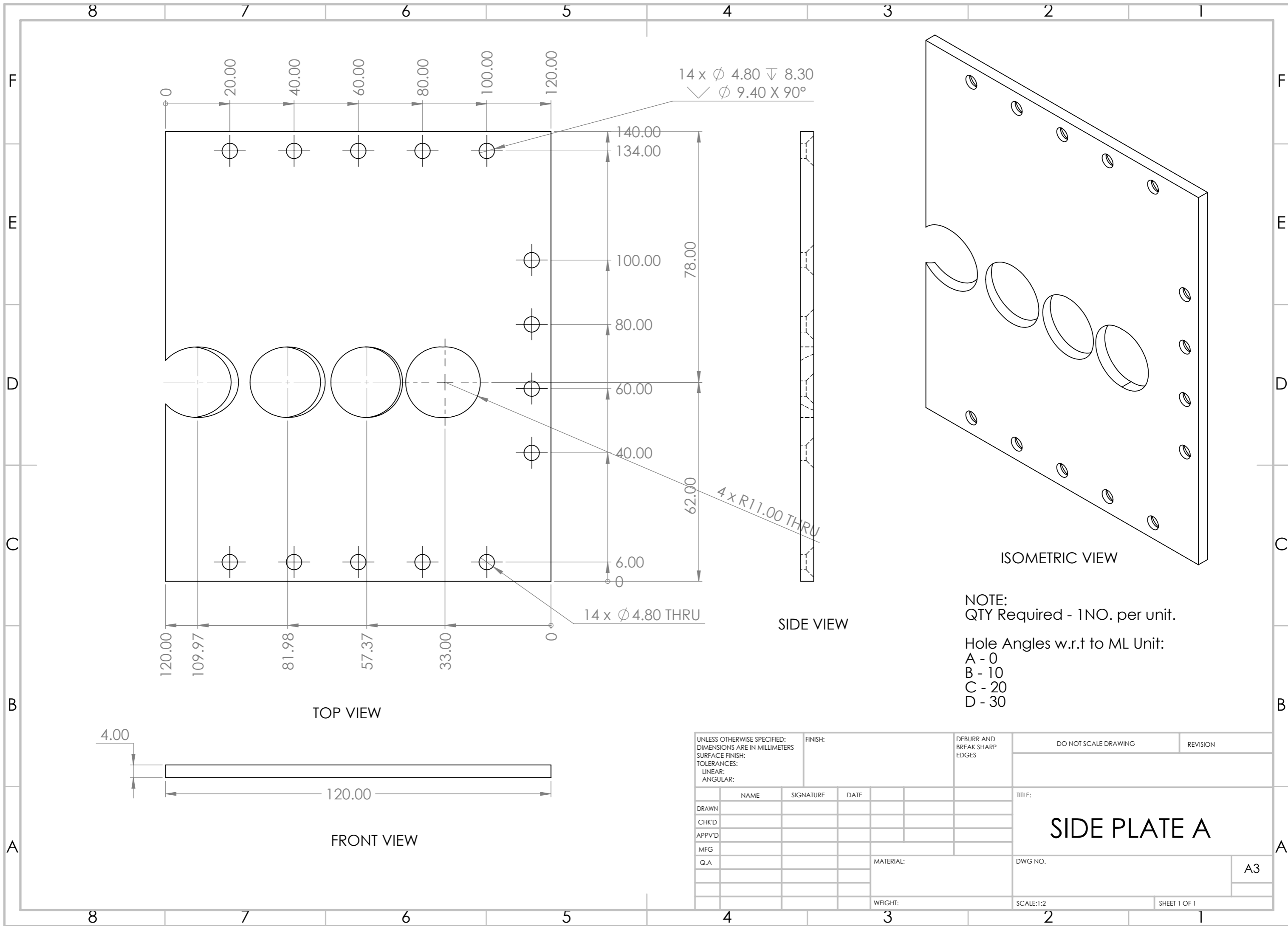

TOP VIEW

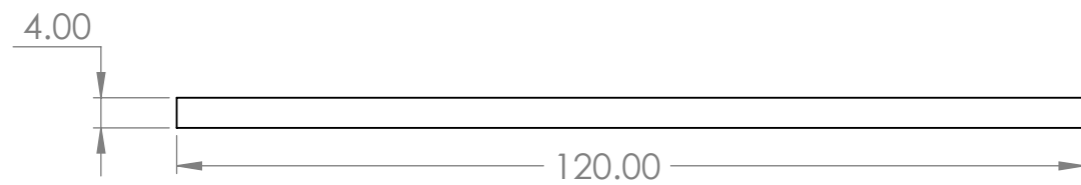

FRONT VIEW

SIDE VIEW

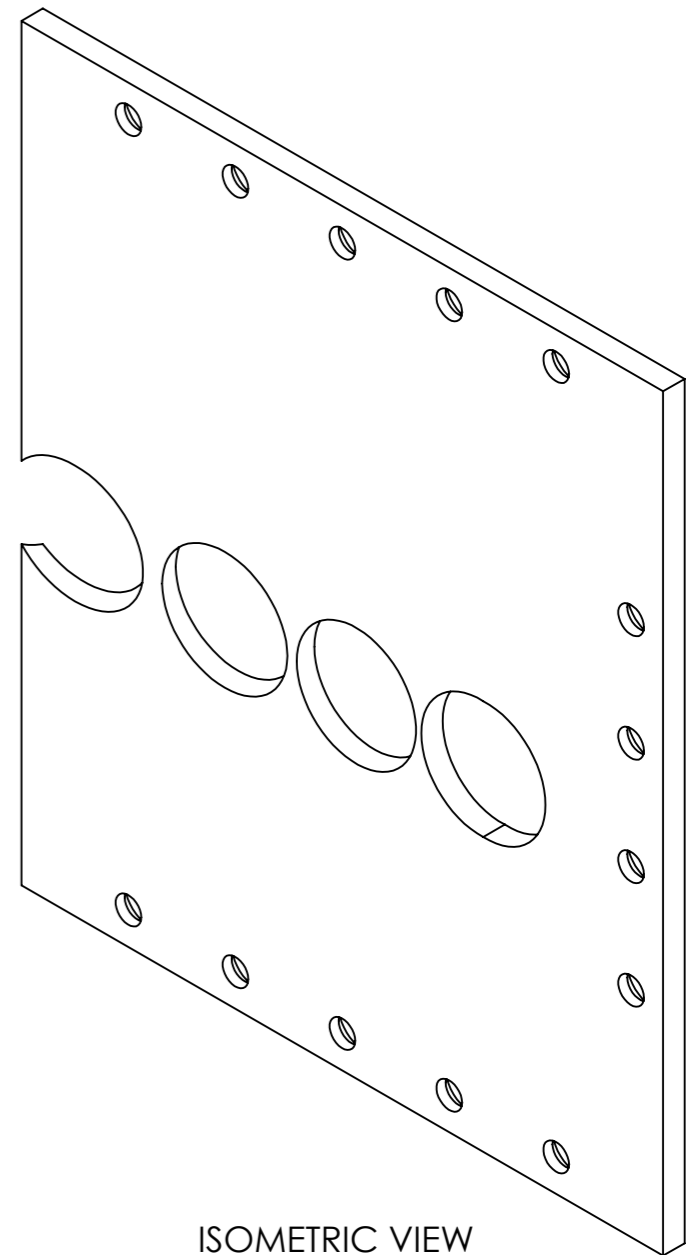

ISOMETRIC VIEW

NOTE:
QTY Required - 1NO. per unit.

Hole Angles w.r.t to ML Unit:
 A - 0
 B - 10
 C - 20
 D - 30

UNLESS OTHERWISE SPECIFIED: DIMENSIONS ARE IN MILLIMETERS SURFACE FINISH: TOLERANCES: LINEAR: ANGULAR:				FINISH:		DEBURR AND BREAK SHARP EDGES		DO NOT SCALE DRAWING		REVISION	
DRAWN						TITLE:					
CHK'D						SIDE PLATE A					
APPV'D											
MFG						DWG NO.					
Q.A						MATERIAL:					
						WEIGHT:					
						SCALE:1:2					
						SHEET 1 OF 1					

A3

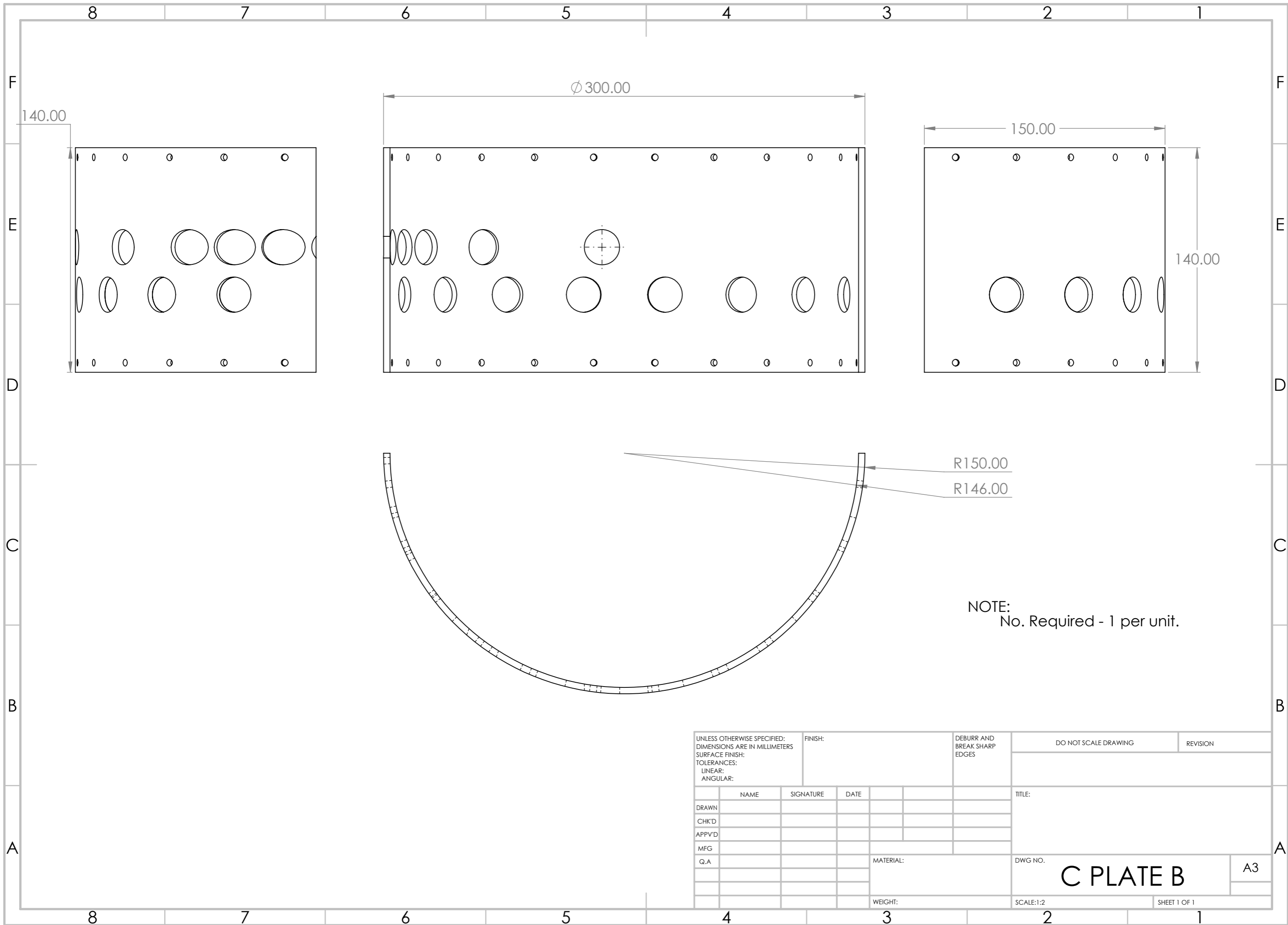

R150.00
R146.00

NOTE:
No. Required - 1 per unit.

UNLESS OTHERWISE SPECIFIED: DIMENSIONS ARE IN MILLIMETERS SURFACE FINISH: TOLERANCES: LINEAR: ANGULAR:				FINISH:		DEBURR AND BREAK SHARP EDGES		DO NOT SCALE DRAWING		REVISION	
DRAWN				NAME		SIGNATURE		DATE		TITLE:	
CHK'D											
APPV'D											
MFG											
Q.A								MATERIAL:		DWG NO.	
										C PLATE B	
								WEIGHT:		SCALE:1:2	
										SHEET 1 OF 1	
										A3	

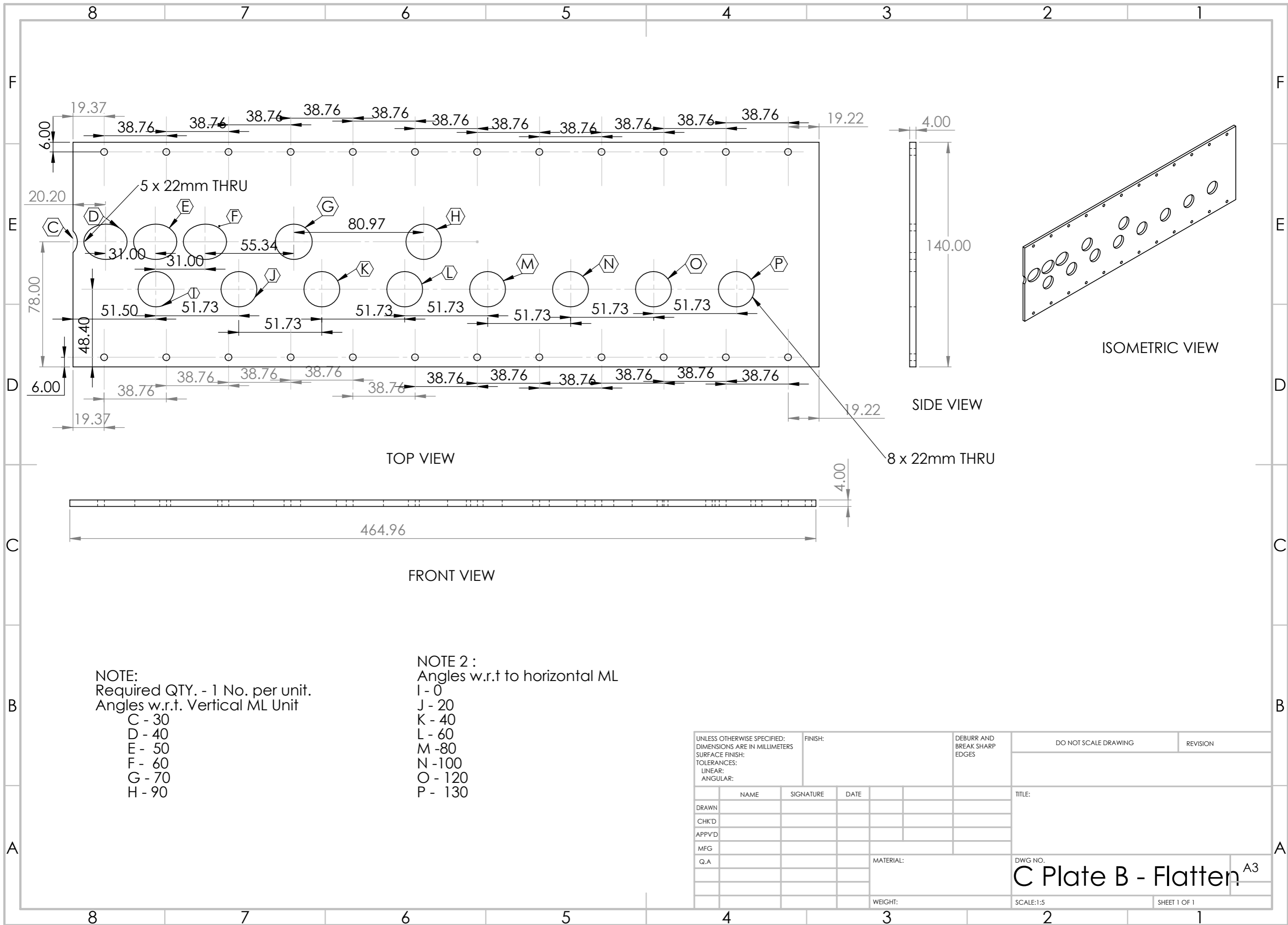

NOTE:
 Required QTY. - 1 No. per unit.
 Angles w.r.t. Vertical ML Unit

C - 30
D - 40
E - 50
F - 60
G - 70
H - 90

NOTE 2 :
 Angles w.r.t to horizontal ML

I - 0
J - 20
K - 40
L - 60
M - 80
N - 100
O - 120
P - 130

UNLESS OTHERWISE SPECIFIED: DIMENSIONS ARE IN MILLIMETERS		FINISH:		DEBURR AND BREAK SHARP EDGES		DO NOT SCALE DRAWING		REVISION	
SURFACE FINISH:									
TOLERANCES:									
LINEAR:									
ANGULAR:									
DRAWN		NAME	SIGNATURE	DATE	TITLE:				
CHK'D									
APPV'D									
MFG									
Q.A					MATERIAL:		DWG NO.		A3
							C Plate B - Flatten		
					WEIGHT:		SCALE:1:5		SHEET 1 OF 1